

SECCION A-A'

E = 1:50

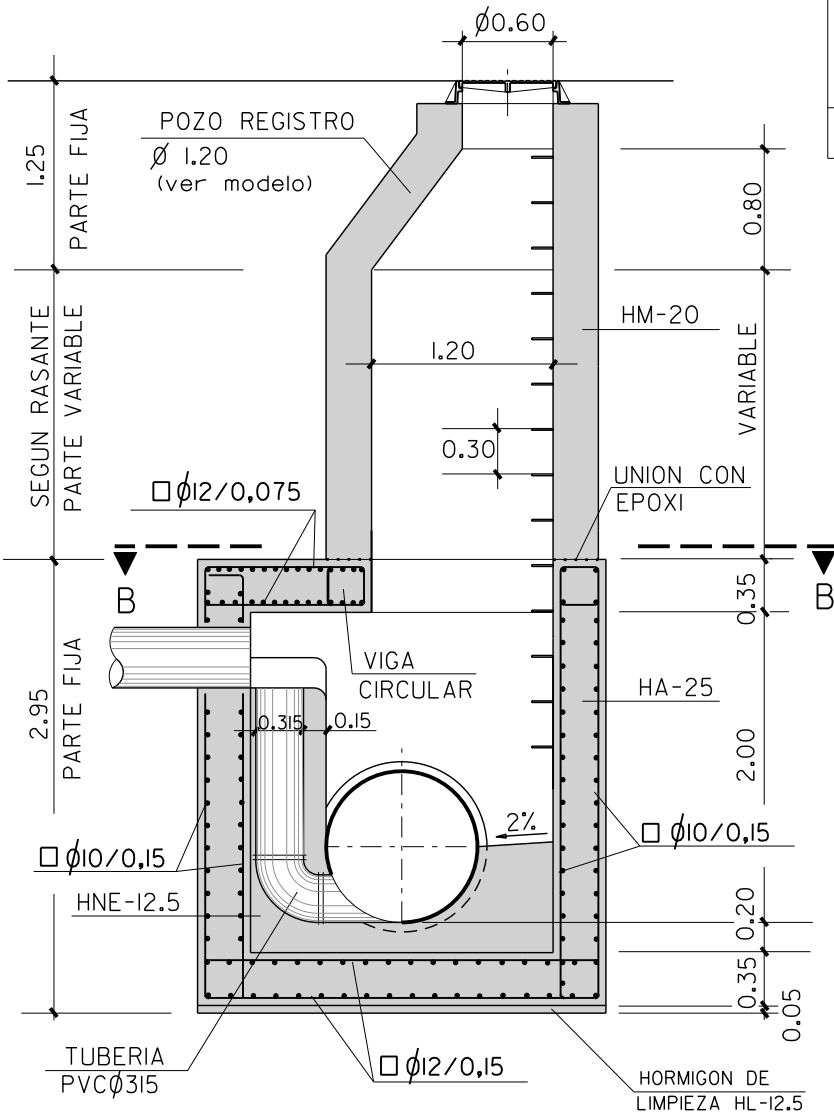

| CONTROL DE CALIDAD | | | |
|--------------------|---------------------------------------|--------|-------------------|
| ACERO | B 500 S | NORMAL | $\sigma_s = 1.15$ |
| HORMIGON | HL-12.5 HNE-12.5 HM-20 HA-25 | NORMAL | $\sigma_c = 1.50$ |
| EJECUCION | NORMAL | NORMAL | $\sigma_f = 1.80$ |

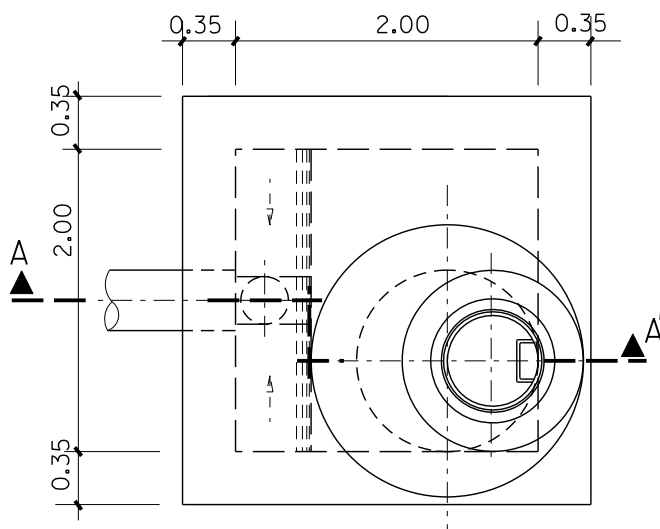

PLANTA

E = 1:50

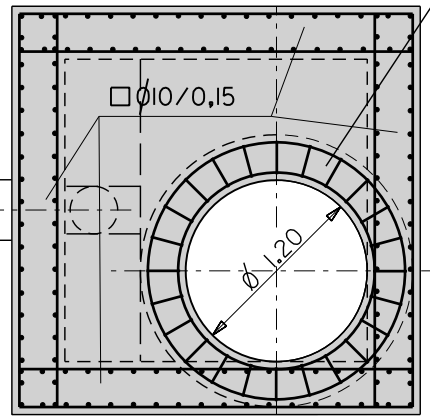

SECCION B-B'

PLANO : POZO DE REGISTRO
CON RESALTO ≥ 150 cm.

| | |
|----------------------------|-------------|
| ESCALA ORIGINAL A4 1:50 | MODELO N° |
| ESCALA GRAFICA | N-14-3 |
| | AGOSTO 2009 |



AREA DE INFRAESTRUCTURAS Y PARTICIPACION CIUDADANA

SERVICIO DE INNOVACION Y DESARROLLO DE INFRAESTRUCTURAS